



World Nuclear Association Annual Symposium
3-5 September 2003 - London

Pebble Bed Modular Reactor The First Generation IV Reactor To Be Constructed

Sue Ion, David Nicholls,
Regis Matzie and Dieter Matzner

Abstract

Substantial interest has been generated in advanced reactors over the last few years. This interest is motivated by the view that new nuclear power reactors will be needed to provide low carbon generation of electricity and possibly hydrogen to support the future growth in demand for both of these commodities. Some governments feel that substantially different designs will be needed to satisfy the desires for public perception, improved safety, proliferation resistance, reduced waste and competitive economics. This has motivated the creation of the Generation IV Nuclear Energy Systems programme in which ten countries have agreed on a framework for international cooperation in research for advanced reactors. Six designs have been selected for continued evaluation with the objective of deployment by 2030. One of these designs is the Very High Temperature Reactor (VHTR), which is a thermal neutron spectrum system with a helium-cooled core utilizing carbon-based fuel.

The Pebble Bed Modular Reactor (PBMR), being developed in South Africa through a world wide international collaborative effort led by Eskom, the national utility, will represent a key milestone on the way to achievement of the VHTR design objectives, but in the much nearer term. The PBMR project has been progressing rapidly over the past few years to a relatively high level of detail. The development programme has included an international team of renowned nuclear companies as well as several highly capable South African companies. Substantial testing has already been completed on key auxiliary systems and components, and a large scale “micro model” of a three shaft recuperated Brayton cycle has been built and commissioned to prove the operational concept. In parallel with the testing of these mechanical systems and components, a comprehensive fuel development, testing and verification programme has begun to support the licensing process. A construction programme for the PBMR has been defined in which a full-sized Demonstration reactor will be built at the Koeberg site in South Africa.

Introduction

The PBMR is a small, modular reactor that is helium cooled and graphite moderated. It uses spherical fuel elements, called pebbles, which are approximately the size of a tennis ball. The genesis of the PBMR design originates with the German high temperature reactor (HTR) development programme of the 1970's and 1980's that included two operational prototypes: the 15 MWe AVR and the 300 MWe THTR. The proof of principle of the pebble bed reactor was demonstrated, as was the basic fuel design in these early German prototypes. The major innovations for the current PBMR design are the direct coupling of the high temperature reactor system to a gas turbine and the achievement of a very high level of passive safety without the use of active engineered systems. The direct cycle gas turbine eliminates the complex and costly steam cycle for power conversion and results in a significantly higher thermal efficiency. Passive safety is accomplished by the use of high integrity particle fuel that has a strong negative temperature coefficient and large thermal capacity. The fuel retains its integrity under high temperature accident conditions and has good resistance to chemical attack, e.g. from water or air ingress. Further, the introduction of an annular core allows fuel decay heat to be conducted through the reactor structures to the vessel cavity and then to atmosphere without the need for AC electrical power or early operator intervention. This provides the reactor with a high degree of inherent safety that is essentially meltdown proof.

The PBMR concept was introduced into the Republic of South Africa (RSA) in 1993 as exploratory evaluations began to determine the feasibility of small nuclear reactors based on this concept to satisfy the anticipated future growth of electrical demand. Small-sized reactors are of interest in South Africa because of the widespread distribution of moderate load demand and the high cost of new transmission across this large country. After an early feasibility study indicated the potential of the concept, a substantial project team was formed within Eskom to perform a detailed feasibility study. Shortly thereafter, international investors, including British Nuclear Fuels plc, were brought into the project and development efforts were accelerated. The South Africa government declared its support for the project and Eskom issued a letter of intent for the PBMR Demonstration plant and ten subsequent commercial modules, assuming the success of the former.

The Environmental Impact Assessment for the Demonstration plant at the Koeberg site on the western cape of South Africa was submitted in 2000 and the record of decision (ROD) in favour of the project was released by the Department of Environmental Affairs and Tourism in June 2003. The Safety Analysis Report Rev 1 was submitted to the National Nuclear Regulator in 2001 and a favourable licensability report was issued in March 2003. Finally, Eskom has publicly announced that it is ready to proceed to the next stage of this "strategic national demonstration project," which includes the detailed design, construction, and commissioning of the first PBMR.

Design objectives

In addition to the obvious high level of safety and competitive economic objectives, which are stated for all advanced reactors, the project has established a number of plant target specifications that are important for the overall performance of the plant. These target specifications are summarized in *Table 1*

Table 1. Plant target specifications

Rated output per module	165 MWe
Continuous stable power range	40-100%
Load rejection without reactor trip	100%
Construction schedule (nominal)	24 months
Planned outage duration and frequency	30 days every 6 years
Plant availability	95%
Seismic (peak ground acceleration)	0.4 g
Emergency planning zone	< 400 metres

The heart of the safety case for PBMR is high quality fuel with extremely low particle failure rates. Previous tests, as part of the German HTR programme, have shown that as long as the maximum fuel temperature remains below about 1600°C, fission products will be contained within the fuel and its TRISO coatings. TRISO fuel consists of a small UO₂ kernel with a porous carbon buffer layer, a dense pyrolytic carbon layer, a very hard silicon carbide layer, and another dense pyrolytic carbon layer. The resulting coated particles are mixed in a graphite matrix, then pressed and sintered into a sphere of six centimetres diameter. This fuel design is shown in *Figure 1*.

Safety approach

The PBMR is based on a relatively simple design, with passive safety features that require no short-term human intervention. Whereas existing commercial reactors use active engineered safety systems, the PBMR achieves its safety through its design approach, the materials used, and the fuel form. The key safety features of the PBMR, in addition to the radionuclide retention capability of the particle fuel, are a small operational excess reactivity, a large negative temperature coefficient, and a passive heat removal capability of the reactor design. The combination of the small excess reactivity and large negative temperature coefficient stops the nuclear fission process with only a moderate temperature rise in the core even if the normal active control and shutdown systems malfunction.

Radioactivity release from a nuclear accident is principally a result of residual decay heat from the fuel after the reactor is shutdown. If this decay heat is not removed, the fuel temperature will increase until its fission product retention capability is degraded. In the PBMR, the removal of decay heat is achieved by conduction, convection, and radiation heat transfer from the fuel particles through the reactor to the environment. The high surface area to volume ratio of the core promotes this heat transfer process and ensures that the core never reaches a temperature at which significant degradation of the fuel can occur. The

combination of the low power density of the core together with the high temperature resistance of the fuel allows this approach to be used.

Design description

The power conversion unit of a PBMR module is contained in four steel pressure vessels that house the reactor core, two turbo compressor units, and the power generation turbine. Interconnecting piping allows for recuperation and cooling of the helium returning to the reactor to achieve the needed gas compression and overall improved thermodynamic efficiency. The pressure boundary of the entire PBMR power conversion unit is shown in *Figure 2*. By utilizing a steel pressure vessel for the reactor instead of the concrete pressure vessel of prior HTRs, decay heat from the core during accident conditions can now be passively rejected to the atmosphere via conduction through the vessel walls to the Reactor Cavity Cooling System.

The thermodynamic cycle of the PBMR is a closed Brayton cycle with recuperation. This cycle with the key fluid parameters is shown in *Figure 3*. Helium exits the reactor at 900°C and passes successively through the high and low pressure turbines that drive the compressors and then to the power generation turbine which is coupled to the main electrical generator. The exhaust helium out of the power generation turbine now passes for the first time through the recuperator transferring its heat to the helium returning to the reactor. The helium coolant then passes through two coolers and the compressors, increasing its pressure to 9 MPa before re-entering the recuperator for the second time prior to returning to the reactor at 482°C. The overall efficiency of this cycle is calculated to be approximately 42% with the current conservative bypass flows, including turbine blade clearances, and cooling water temperatures.

Core design

The PBMR core consists of approximately 452 000 fuel spheres packed in an annular geometry with an inner radius of 1.0 metre and an outer radius of 1.85 metres. The active height of the core is 11.0 metres, resulting in a relatively low power density of 4.8 MWt per cubic metre. This geometry and power density were selected so that the passive heat removal of the core could be achieved while maintaining good reactivity control and shutdown margin.

High plant availability is achieved with on-power refueling. The pebbles gradually move downward in the core bed from top loading locations and exit via one of three de-fueling chutes at the bottom of the bed. After exiting the core, the pebbles are assayed for burnup and checked for general spherical integrity. If insufficient burnup has been achieved, a pebble is returned to the top of the core by the pneumatic Fuel Handling and Storage System. On average, pebbles make about six passes through the core before being placed in spent fuel storage tanks. The peak pebble burnup in the Demonstration plant is approximately 95 000 MWd/t at an equilibrium enrichment of 9.6 wt% U235.

The inner and outer reflectors of the annular core are composed of graphite blocks that provide the geometrical boundary of the core, reduce the temperatures that the metallic internals and RPV see, provide moderation and reflection of neutrons, and provide locations for the control systems. In the outer reflector (as shown in *Figure 4*) are housed the 24 Control Rod System locations. The inner reflector houses the eight Reserve Shutdown System locations where borated graphite spheres are inserted. These systems provide two independent means of achieving reactor shutdown to cold conditions defined as 100°C.

Turbo machinery design

The turbo machinery for the PBMR has been optimized to strike a balance among efficiency, proveness/technological challenge, cost, and ease of performing maintenance. Instead of trying to integrate the power turbine/generator and the two turbo compressor machines onto the same shaft, PBMR selected three separate shafts. This allowed smaller, higher speed turbo machines with simpler rotor dynamics and balancing. The individual machine speeds could be optimized for their designs and smaller pressure vessels could be used that retained the entire pressure boundary within the current manufacturing capability of existing heavy vessel nuclear shops. The three-shaft design also improves maintenance of the different components because there is easier access to each. A single-shaft design requires removal of the main power generator each time that maintenance is performed on any turbo machinery.

A major change to the design of the power turbine generator compared to other direct cycle reactor applications is the incorporation of a dry gas seal between the turbine and the generator. This allows the use of a conventional axial oil thrust bearing to support the generator. Avoided is the need to develop an axial magnetic, catcher bearing that was very problematic. Only the radial bearings on the power turbine are magnetic and these are within current state-of-the-art technology. Further, the use of the dry gas seal allows the use of a conventional air-cooled main power generator, eliminating anticipated problems with the circulation of radioactive graphite dust within a submerged generator and high-tension penetrations through the pressure boundary.

Of course, there are some disadvantages to this turbo machinery strategy compared to the single-shaft design. The principal disadvantage is the higher helium coolant bypass flow, which reduces the overall plant efficiency slightly. Secondly, a more complex control system with multiple bypass paths must be used to compensate for fast transients and load follow operations. However, on balance, it is felt that the reduction in development risk and the ease of performing maintenance outweigh these disadvantages, particularly for the Demonstration plant. Further design optimization will naturally be conducted as experience is gained in the construction and operation of the early PBMR plants.

Building arrangement

The building arrangement for a single PBMR module that will be constructed for the Demonstration plant in South Africa is shown in *Figure 5*. It consists of a reinforced concrete confinement structure, called the citadel, which houses the

power conversion unit, which is located inside a more conventional concrete building that houses all of the auxiliary equipment. The function of the citadel is to protect the nuclear components of the power conversion unit from external missiles and to retain the vast majority of fission products that might be released in the event of a reactor accident. It is a confinement structure rather than a high pressure retaining containment structure because of the fundamental design bases of the PBMR. Since the PBMR is a gas-cooled reactor rather than a water-cooled reactor, the coolant (helium) does not flash to steam upon a reduction in pressure and therefore does not have a rapid high-energy release with a large pressure buildup in the confinement. In addition, there is very little radioactivity in the helium during normal operations and the subsequent release of fission products during an accident (if any) is very slow. Thus, it is desirable to vent the pressure from the confinement early in an accident to ensure the confinement's integrity later in the accident when fission products might be present. Depending on the size of break in the reactor pressure boundary, the venting occurs through the HVAC system, through the confinement stack, or through blowout panels.

The conventional module building has an overall height of 55 metres of which 22 metres are below ground level. The width of the building is 36.4 metres and the length is 62.9 metres. In addition to surrounding the citadel, this building incorporates the Spent Fuel System, the Fuel Handling System, the Helium Inventory Control System, the HVAC System, all the electrical and I&C systems, the main control room, and all the other auxiliary systems needed to support the power conversion unit. This building also provides a good degree of protection for the overall plant in general and the power conversion unit in particular. External missiles must penetrate through multiple floors and/or walls to reach the citadel.

Support systems

The two major support systems of interest are the Fuel Handling and Storage System (FHSS) and the Helium Inventory Control System (HICS). The FHSS is a pneumatic system that uses helium to circulate the fuel pebbles as necessary for refueling or storage. It has been designed to operate for 12 hours per day at a maximum circulation rate of 600 fuel spheres per hour. It is rated at the full power conversion unit operating pressure of 9 MPa and a maximum operating temperature of 260°C. There are three separate de-fueling chutes and fueling lines that circulate fuel back to the top of the reactor. There are various filters, blowers, and valve blocks that ensure the system operates reliably and that the fuel pebbles are transferred to their proper destination depending on their condition (burnup and/or integrity). The spent fuel is stored in below grade tanks within the conventional module building. The storage capacity is 6 million spheres, which is selected to accommodate all spent fuel on site for the life of the plant.

The Helium Inventory Control System is a pneumatic system that manages the helium inventory in the power conversion unit and the remainder of the plant. It has a storage capacity of 10.4 metric tonnes at a pressure up to 11.1 MPa. It is designed to remove gaseous impurities, e.g. nitrogen, hydrogen, carbon dioxide,

etc. and to filter graphite dust particles. The system is designed to replenish the daily design leakage of helium up to 7 kilograms per day.

System and component testing

A substantial amount of testing of the PBMR systems and components has already occurred, is in process, or is planned for the near-term. The purpose of these tests is to get independent verification of the anticipated performance of the plant once constructed. Where the design features are applicable or the experience relevant from the German HTR programme, these tests build on the wealth of experimental data available. In some cases, the testing will help make final design decisions on key design parameters.

As part of the core design verification and validation programme, a series of reactor physics experiments were performed in the ASTRA critical facility at the Kurchatov Institute in Moscow. As core design changes are planned and/or additional information desired, e.g. to support licensing, further tests will be performed at this facility.

Extensive FHSS and reactivity control system tests have been conducted already at IST in Pretoria, RSA. These include individual FHSS component tests of valve blocks, the gas conveyor system, storage tank packing and loading, pebble burnup sensors and associated instrumentation. Also, a scale model pebble flow mock-up has been operated to investigate the pathways of individual pebbles within the bed, the desired number and geometry of the de-fueling chutes, and any propensity of pebbles to form stagnant regions in the bed.

In the reactivity control system area, tests have been run on both the Reserve Shutdown System (RSS) and the Rod Control System (RCS). The RSS tests included Small Absorber Sphere (SAS) manufacture tests and SAS transport tests. For the RCS, tests have been completed on rod SCRAM shock absorbers and the operation of the control rod drive mechanisms.

Since a three-shaft recuperative Brayton cycle had never before been built and operated, a “micro” model that mimics the PBMR system was designed, built and commissioned at the University of Potchefstroom in South Africa. The model, which has a mass of over 35 metric tonnes, simulates all the key components in the PBMR power conversion unit. It has an electric heater in place of the reactor core and uses nitrogen as a coolant instead of helium. Thus far, the “micro” model has performed flawlessly and the initial startup agreed within 1°C of the predicted bootstrap temperature. It thus confirms the integrated operability of the three-shaft recuperative Brayton cycle and the analytical tools being used to predict its performance.

A full-scale turbine test facility is planned on the premises of the turbo machinery supplier, Mitsubishi Heavy Industries, to verify analyses and obtain operational maps for use in simulator studies, and to qualify the electromagnetic bearings.

A large scale Helium Test Facility will be constructed in South Africa starting in mid-2005 to test many of the key components at full PBMR operating temperature

and pressure in a helium environment. FHSS, RCS, and RSS components will be tested for operability and endurance. This will require six large pressure vessels, the tallest of which is over 25 metres in length and weighs 82 metric tonnes. Full-size helium valves will be tested as well as blowers, coolers and special tools to perform maintenance. In addition, graphite erosion tests will be conducted to determine the effect of high temperature helium flow on different geometry graphite blocks.

A comprehensive fuel irradiation programme is planned to start in late 2004, with the irradiation of the initial particle fuel compacts in the IVV2M reactor in Russia. A series of six different irradiation tests are planned in a combination of the IVV2M reactor and the South Africa SAFARI reactor. Burnup values ranging from 4% FIMA to 10% FIMA are planned on actual production fuel intended for the PBMR Demonstration plant. Other irradiation campaigns are being considered, depending on the data needs and the availability of joint funding. In addition to this fuel irradiation programme, a graphite and carbon fibre composite irradiation programme is also planned to gain performance data on the reflector materials.

There is an extensive qualification and verification programme for the fuel manufacturing equipment. Laboratory tests are already ongoing for fuel kernel formation, coating, and pebble pressing at the Nuclear Engineering Corporation South Africa (NECSA) facility in Pelindaba. These tests are demonstrating the process steps and controlling variables in the manufacturing process. In addition, quality control tests are being conducted to gain experience in this vital function and to explore the best procedures to ensure reproducibility of the manufacturing process steps.

Finally, during startup and commissioning of the PBMR Demonstration plant, an extensive testing programme is planned to verify the operating characteristics and response of the plant to selected transients. These will help to prove the specified safety features and to confirm predictions of operations under a variety of conditions.

Demonstration plant schedule

The schedule for the PBMR Demonstration plant in South Africa is shown in *Figure 6*, based on the assumption of full project release on 1 January 2004 to major suppliers to complete the detailed design and to procure long-lead materials. With this occurring, site excavation would begin in late 2005, with civil construction commencing mid 2006. The manufacture of the main power unit pressure boundary would begin in early 2005 and the turbo machinery in mid 2006. It is now anticipated that fuel load would start in early 2009, the plant would be synchronized to the grid in late 2009, with turnover of the plant in 2010 after an extensive testing programme.

Transition to the Generation IV Very High Temperature Reactor (VHTR)

The current PBMR design goes a long way towards satisfying the goals of the VHTR. The principal goal is to achieve coolant outlet temperatures above 1000°C so that it can supply process heat to a broad spectrum of high-temperature and energy-intensive, non-electric processes. The VHTR may also incorporate electricity generation equipment to meet co-generation needs.

The PBMR currently has an average coolant exit temperature of 900°C under normal operating conditions. This was set to ensure that the peak fuel temperature remains well below the 1250°C target where silver and caesium fission products begin to diffuse through the silicon carbide fuel particle coatings. These two elements contribute to the radioactive dose during maintenance and therefore it is desirable to keep their concentrations as low as possible. The PBMR design coolant exit temperature can be easily raised to 950°C for process heat applications and still maintain the peak fuel temperature comfortably below the above target value with the same TRISO-coated UO₂ fuel that is currently in the design and scheduled for testing starting in 2004. This is possible because of the conservative, low power density (averaging 4.8 MWt per cubic metre) being used in the Demonstration plant; and the intimate/close proximity of the coolant to the fuel particles, which results in a low peak-fuel-to-coolant exit temperature difference. With further fuel development and verification, as programmed into the PBMR long-term technology plan, average outlet temperatures in excess of 1000°C are possible. This development may include optimization of the various coatings on the UO₂ particles and/or an alternate fuel composition, e.g. UC. This is a natural part of the PBMR long-term development programme to improve fuel and plant performance.

Other areas of development come into play as the temperatures of the plant increase. These mainly focus on extending the high temperature capability of existing or alternate materials. The most obvious materials for improvement include the core structures (particularly the metallic internals), the various interface materials (particularly for process heat applications), turbo machinery blades, and possibly pressure boundary materials. These components see the high temperatures that stretch their current operating duty during transient events, but not during normal operations.

The core barrel is one of the most limiting components during the design basis event, the depressurized loss of cooling. It can see temperatures that exceed normally approved/accepted values that allow continued operation after such events. There are ways of mitigating these potentially high temperatures - some are analytical and some are based on system design changes. However, it would be preferable to use better materials with the same system design.

Another material that will be used in the PBMR that will have broader industry application is carbon fibre composites. This material is currently used in the outer reflector as restraint straps, but could be used more extensively once qualified in a high temperature irradiation environment. Current plans are to proceed with this qualification as part of the PBMR Demonstration plant development.

As the PBMR is utilized for other applications, e.g. hydrogen generation, intermediate heat exchangers (and possibly other components) will be needed that can accommodate both high temperatures and high thermal stresses. These components will require qualification in the associated severe environments they will be operating. Fortunately, the PBMR team has had to investigate some of these components for their current design, e.g. the recuperator, and they are familiar with the requirements for and trade offs of these components. As the PBMR is commercialized, i.e. after the Demonstration plant is commissioned, an optimization phase will undoubtedly look at many of these issues to improve the performance of the design.

An area of potential future development is in the turbo machinery. It can see higher than normal temperatures during certain transients, such as load rejections. Currently, bypass valves are used to prevent overheating of these components. Large temperature gradients can occur on these valves, which puts their long-term operation in some jeopardy. As an alternative, the materials in the turbo machinery, particularly the blade materials, can be upgraded to higher temperature duty.

The higher temperature employed in the VHTR may require the development of new pressure boundary materials, although it is possible that existing materials may be suitable, if appropriately qualified. The PBMR design avoids contact between the hot gas and a key pressure boundary component, the reactor pressure vessel. However, future developments of the PBMR and the VHTR would benefit from the qualification of higher temperature pressure boundary alloys.

Conclusion

The PBMR is at a very advanced stage of development already and will be proceeding to the detailed design and procurement stage very soon. It has a customer with a designated site for the Demonstration plant and a supporting positive record of decision for the Environmental Impact Assessment. Thus, the PBMR will be the first advanced non-water reactor to be built in this decade.

Further, the PBMR design already has many of the attributes that are desired for the VHTR, and an acknowledged need and desire for a long-term development programme that will address many of the high temperature issues identified for the VHTR. Thus, the PBMR has the potential in the mid-term of becoming the VHTR by the fact that it will meet the stipulated design criteria for this Generation IV concept.

Figure 1. PBMR fuel element design

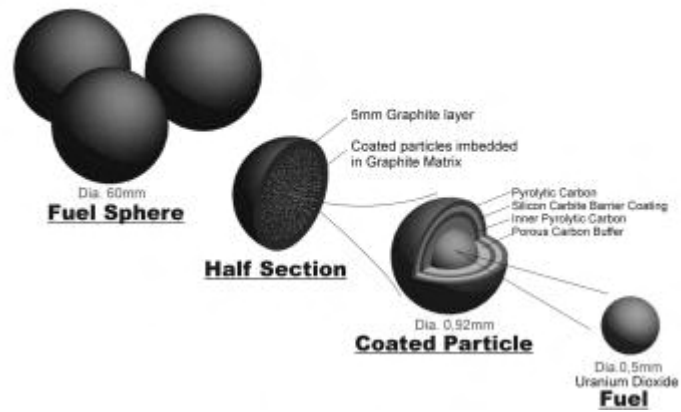

Figure 2. PBMR pressure boundary

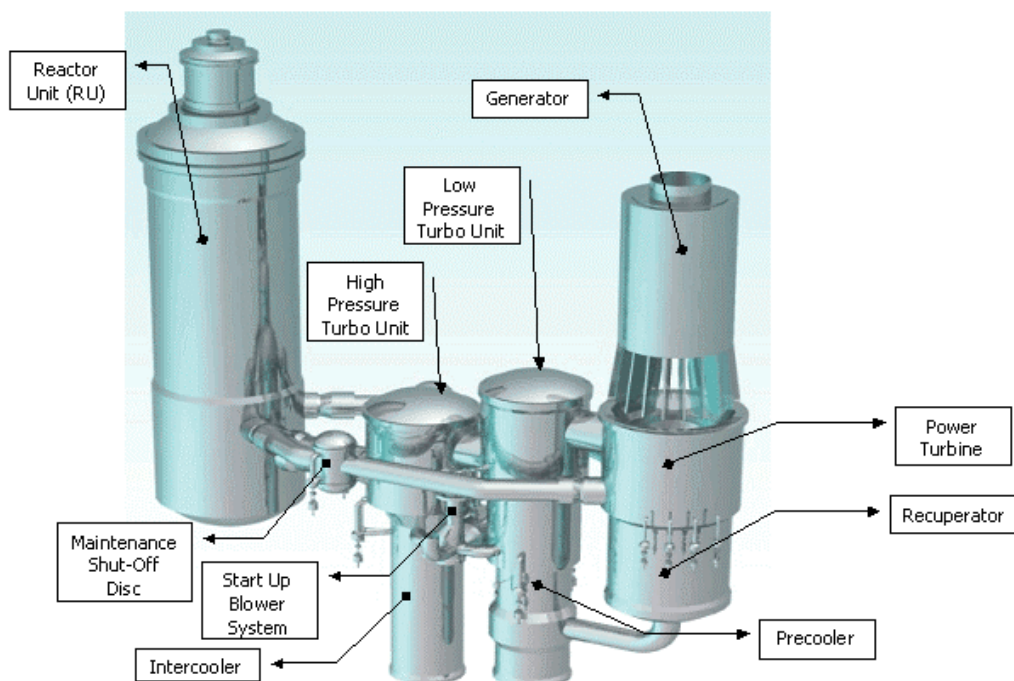

Figure 3. PBMR thermodynamic cycle

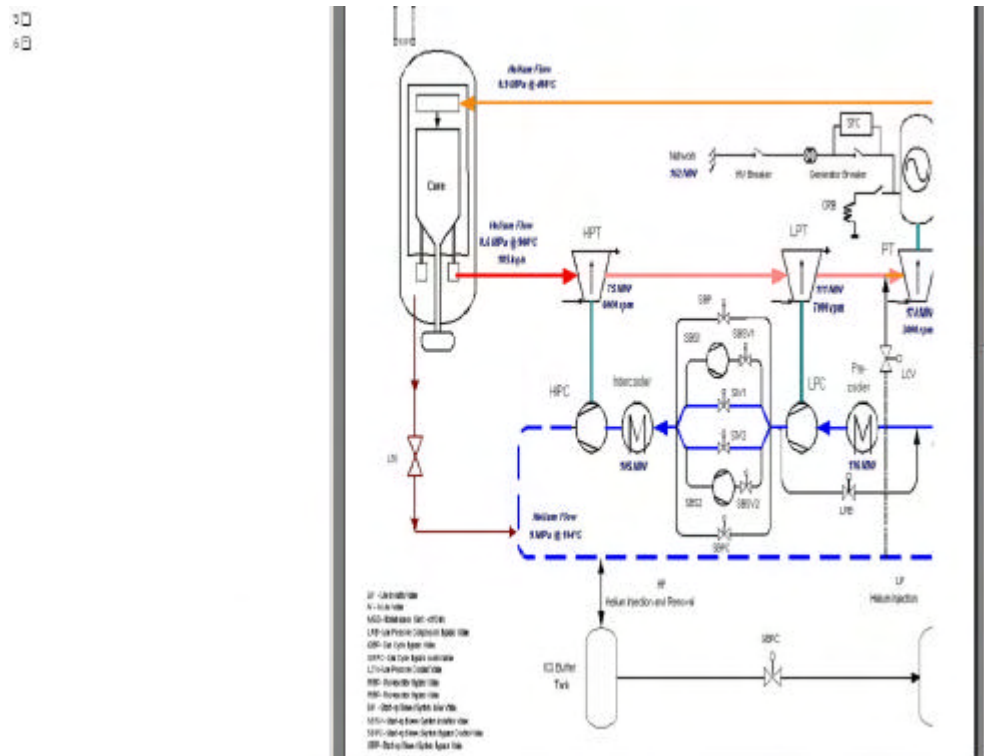

Figure 4. Core configuration

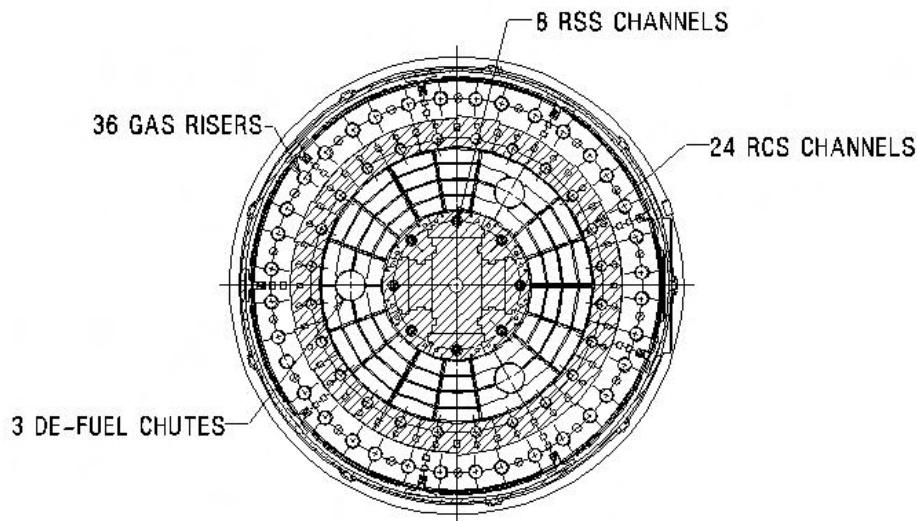

Figure 5. PBMR single module building

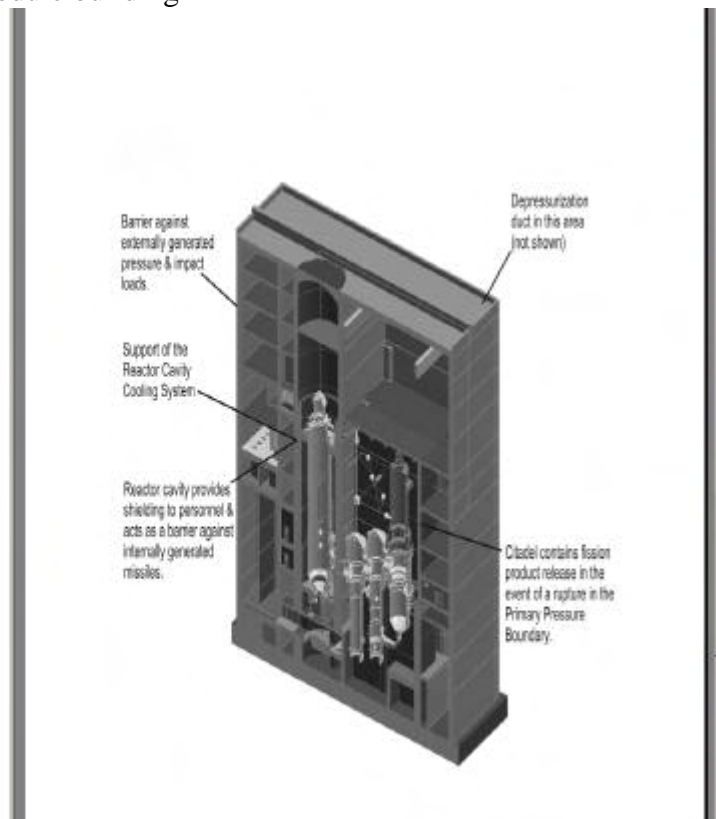

Figure 6. PBMR demonstration plant schedule
(Applicable for January 2004 Project Release)

